

(4/10/2005)

3M 1700 Overhead Projector

Illustrated Parts Breakdown

Beige colored machines:
1706, 1707, 1710, 1715

Gray colored machines:
1711, 1720, 1730, 1740, 1745, 1760,
1765, 1780

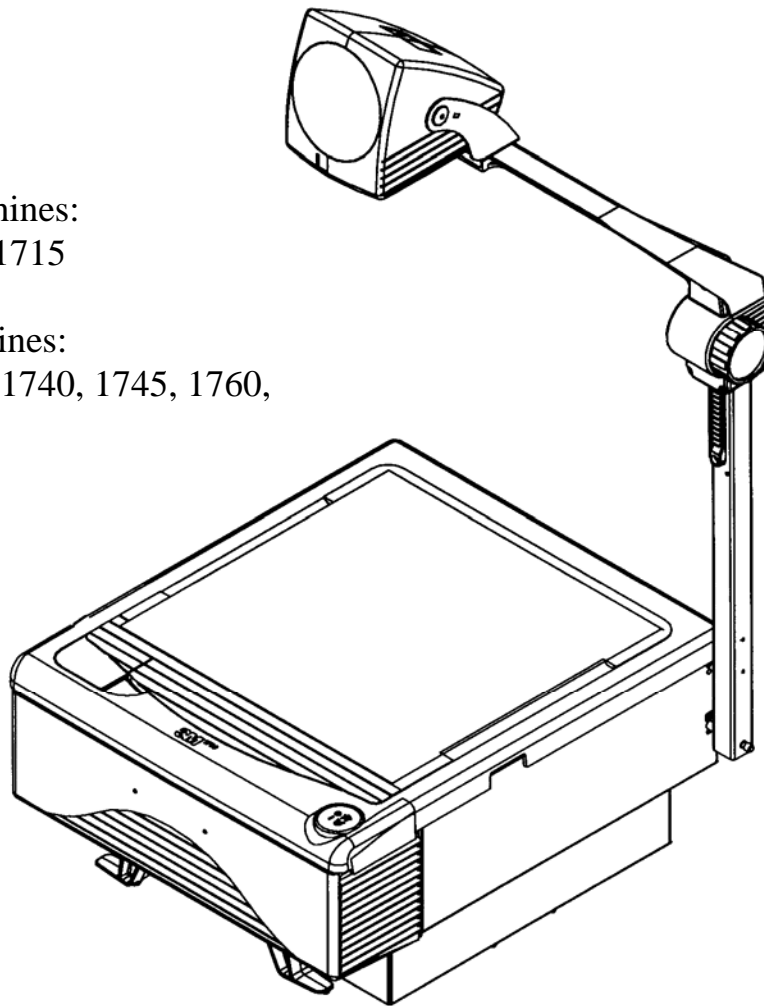

3M Visual Systems Department
6801 River Place Boulevard
Austin, Texas 78726-9000
www.3m.com/meetings

OHP Service Documentation Resource
Copyright © 2005. All Rights Reserved
78-6970-7536-0

Revision History

Original Issue date: 1998

The release date, revision level, pages changed and a description of the modifications are listed below.

Revision	Date	Page(s) Changed	Description
Rev A	1998	All pages	First edition released.
Rev B	4/2001	All pages	Added Gray machine references
Rev C	10/2001	Figure 5, Pages 13-14	Top Cover individual parts combined.
Rev D	5/2002	All pages	Updated part nbrs and assembly nbrs. Added rev history page.
Rev E	9/2002	Quick Ref Parts Index and Figure 1, Pages 5 and 6 Figure 11, Page 25	Added new Head Assemblies for Gray machines. Removed Head Assembly part nbrs for Beige machines. Added new Roll Film Kit.
Rev F	4/2003	Figure 3, Page 10	Updated part numbers for items 3 and 10.
Rev G	3/2005	All pages	Added new Arm/ Focus, Top Cover Assemblies. Updated kits, part nbrs, and Appendix information.

All rights reserved. No part of this book covered by the copyrights hereon may be reproduced or copied in any form or by any means-graphic, electronic, or mechanical, including photocopying, taping or information storage and retrieval systems-without written permission of 3M Visual Systems Department.

Table of Contents

INTRODUCTION	1
QUICK REFERENCE PARTS INDEX	2
SECTION 0. MACHINE OVERVIEW.....	3
SECTION 1. HEAD ASSEMBLY	4
SECTION 2. ARM AND FOCUS ASSEMBLY (BEIGE COLOR)	6
SECTION 3. ARM AND FOCUS ASSEMBLY (GRAY COLOR) (SERIAL NUMBER 170006497 AND BELOW)	8
SECTION 4. ARM/FOCUS/POST ASSEMBLY (GRAY COLOR) (SERIAL NUMBER 170006498 AND ABOVE)	10
SECTION 5. POST ASSEMBLY	11
SECTION 6. TOP COVER ASSEMBLY (SERIAL NUMBER 170000988 AND BELOW).....	13
SECTION 7. TOP COVER ASSEMBLY (SERIAL NUMBER 170000989 AND ABOVE)	15
SECTION 8. BASE ENCLOSURE	16
SECTION 9. CONTROL MODULE	18
SECTION 10. LAMP HOUSING (SINGLE)	20
SECTION 11. LAMP HOUSING (DUAL).....	22
SECTION 12. COOLING FAN.....	24
SECTION 13. ACCESSORIES	26
SECTION 14. WIRE JUMPERS	27
SECTION 15. HARDWARE KIT (NO PICTURE).....	29
APPENDIX A – 1700 SPECIFICATIONS	30

This page is intentionally blank

INTRODUCTION

This Illustrated Parts Breakdown (IPB) Manual contains the information necessary to locate and identify assemblies, sub-assemblies, and specific parts of the 1700 Overhead Projector.

Part Numbers

All components available on a replacement basis are listed with their 3M identification number. The parts identification list opposite each illustration provides the description adequate to identify components. If the component is available only as part of the next higher assembly, the description column provides the next higher assembly description or identification number.

Locating and Identifying a Part

If physical appearance and general location of an item are known:

1. Use the IPB Section Titles to help determine which assembly or sub-assembly includes the item.
2. Refer to the view for the assembly or sub-assembly and locate the item on the exploded view. Match the part callout number to the corresponding number in the parts list.
3. Parts shown inside a dashed box can only be ordered as an assembly. Any part or mounting hardware shown outside the box is not included with the assembly.

Machine Identification Plate

The serial number plate for the 1700 is located on the inside wall of the projector. The Machine Identification Plate is divided into the following components:

1. Product Name: The specific version number of the projector.
2. Model Number/Alpha Code: The series number of the projector followed by a three or four character alpha code identifier. The Alpha Code indicates the design level, specific product characteristics, power cord or distribution specific to a country.
3. Lamp: The electrical rating of the lamp.
4. MFG Code: The MFG Code indicates the year and quarter the projector was built. (See the example to the right):
5. S/N: The serial number assigned to this projector.

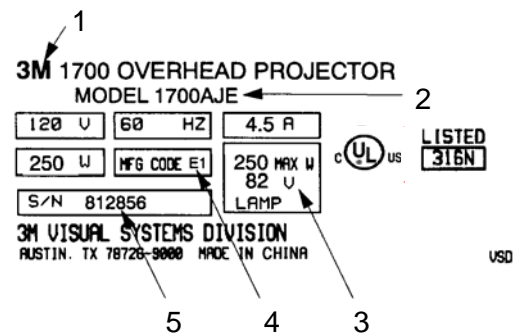

MFG Code			
Letter		Digit	
E	1997	1	Jan-Mar
F	1998	2	Apr-Jun
H	1999	3	Jul-Sep
J	2000	4	Oct-Dec
K	2001	1	Jan-Mar
A	2004	2	Apr-Jun
C	2005	3	Jul-Sep

Ordering Parts

When ordering parts, include the following information:

1. Machine model number and serial number.
2. Parts identification number.
3. Part description.
4. Quantity required.

For U.S. retail customers: Call 1-800-650-8429, or fax 1-800-650-9268. Dealers: Refer to Dealers Guide.
3M Subsidiaries: Contact Export Operations.

Quick Reference Parts Index

Description	Part Number	Section No.	Item No.
Blade, Fan	78-8054-1823-9	12	1
Diode Kit, Inline	78-8054-1836-1	12	8A
Fresnel Lens, Dual-Element	XO-0038-0820-1	7	3
Fuse, 5 Amp, 5x20mm (Brazil only)	26-1005-9599-5	12	3
Singlet Head Assembly (1720, 1760, 1765 Gray color)	78-8120-8554-2	1	8A
Doublet Head Assembly (1730, 1780 Gray color)	78-8120-8555-9	1	8B
Open Head Assembly (1711, 1740, 1745 Gray color)	78-8120-8556-7	1	9
Lamp, Projection, ENX, 82V (Single)	78-8011-1186-1	10	3
Lamp, Projection, ENX, 82V (Dual)	78-8011-1186-1	11	4A
Lamp, Projection, FXL, 82V (1745 and 1765)	78-8073-7100-6	11	4B
Motor, Fan, 120V	78-8120-2914-4	12	7
Power Cord, 10 ft., 120V	78-8079-8822-1	8	4A
Resistor, 1.2 Ohm, 0.25 tab	78-8073-7127-9	9, 10	5A, 13
Socket, Single Lamp, ENX	78-8079-8820-5	10	2
Socket, Dual Lamp, Black	78-8073-3017-6	11	3
Thermostat, Safety (ENX)	78-8079-8872-6	10	7
Top Cover Assembly, Single (Beige color)	78-8114-9027-1	6	1A
Top Cover Assembly, Dual (Beige color)	78-8114-9021-4	6	1B
Top Cover Assembly, Basic (Gray color)	78-8120-8572-4	7	1A
Top Cover Assembly, Lamp Changer (Gray color)	78-8120-8573-2	7	1B

IMPORTANT NOTICE

**3M reserves the right to sell or furnish NEW OR RECONDITIONED PARTS.
New and reconditioned parts are covered by the same 3M new parts limited warranty.**

Section 0. Machine Overview

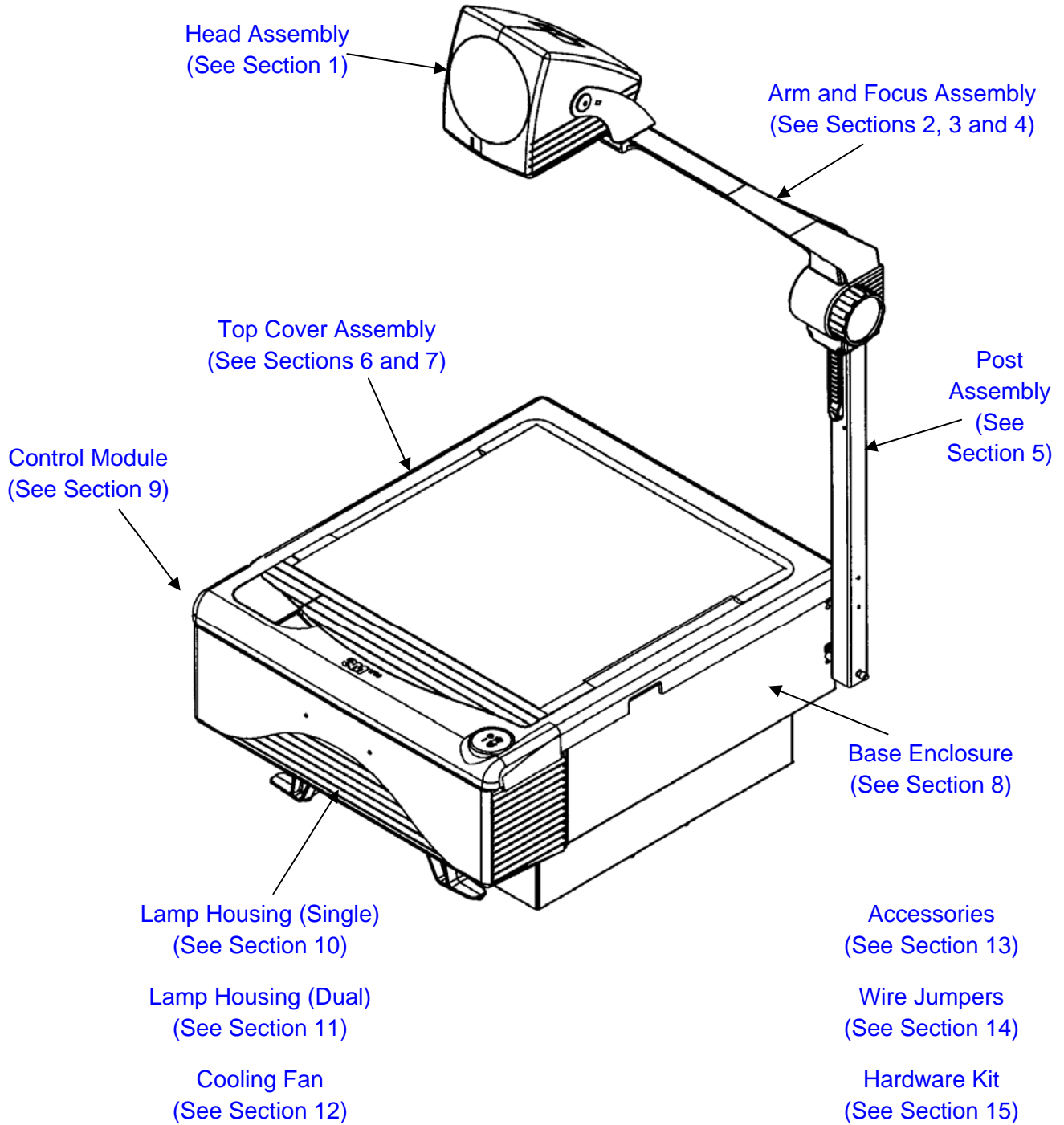

Section 1. Head Assembly

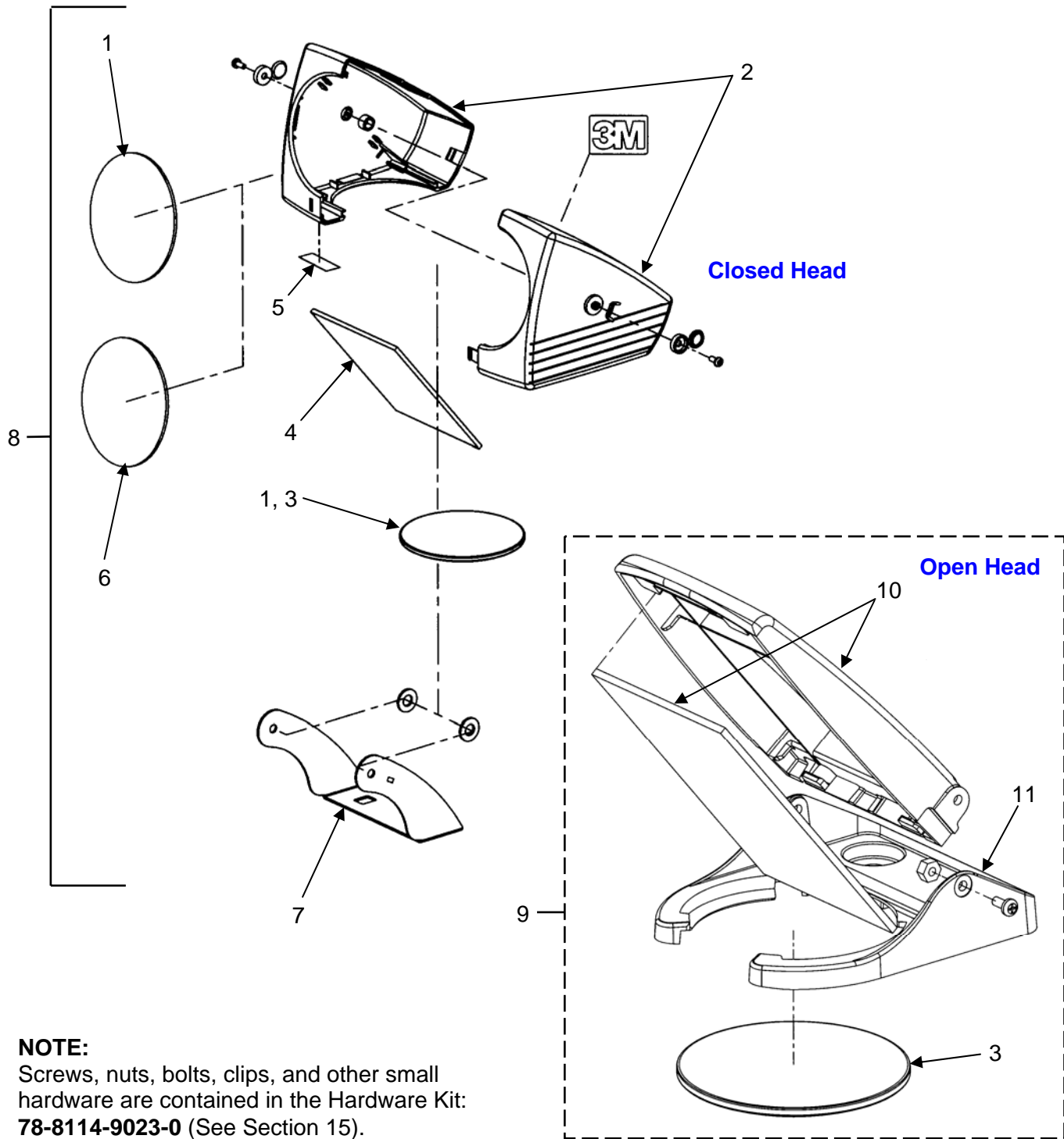

NOTE:
Screws, nuts, bolts, clips, and other small hardware are contained in the Hardware Kit: **78-8114-9023-0** (See Section 15).

Head Assembly Parts List

Item No.	3M Part Number	Description	Qty.
1	78-8114-8795-4	Lens, Doublet Element	2
2A	78-8120-2934-2	Head Halves, Singlet (Beige color)	1
2B	78-8120-2935-9	Head Halves, Doublet (Beige color)	1
2C	78-8120-8451-1	Head Halves, Singlet (Gray color)	1
2D	78-8120-8464-4	Head Halves, Doublet (Gray color)	1
3	78-8014-8951-5	Lens, Wide Angle, 293mm (Singlet Head only)	1
4	78-8114-8812-7	Mirror	1
5	78-8120-3192-6	Label, Head	1
6	78-8120-2927-6	Lens, Head	1
7	78-8120-3072-0	Bracket, Head Mount, Closed Singlet (Gray color only)	1
8A	78-8120-8554-2	Singlet Head Assembly (1720, 1760, 1765 Gray color)	1
8B	78-8120-8555-9	Doublet Head Assembly (1730, 1780 Gray color)	1
9	78-8120-8556-7	Open Head Assembly (1711, 1740, 1745 Gray color)	1
10	78-8120-8501-3	Open Singlet Mirror Assembly	1
11	(Not available)	Housing, Lens, Split, Open Singlet	1

Section 2. Arm and Focus Assembly (Beige color)

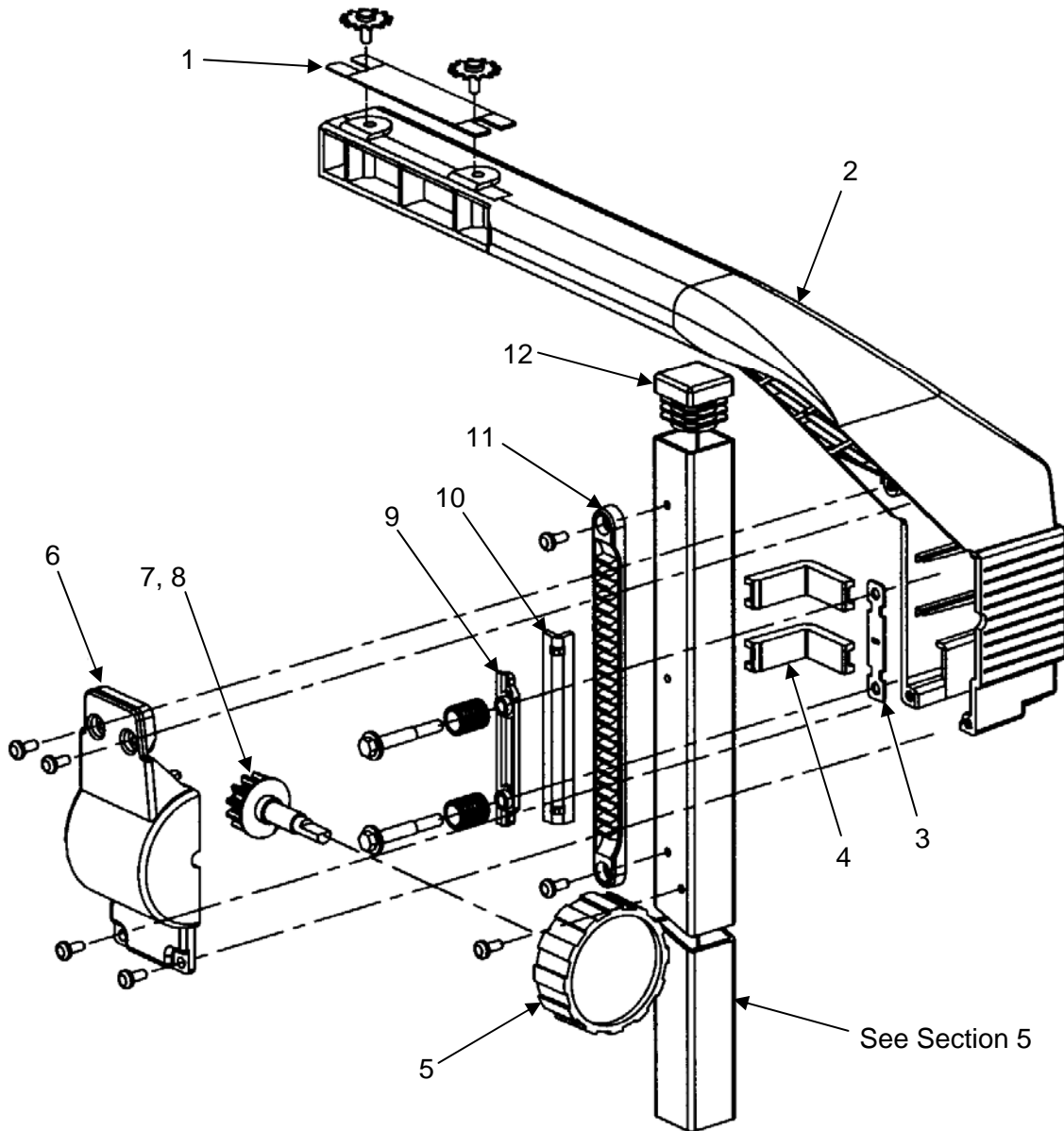

NOTE:
Screws, nuts, bolts, clips, and other small hardware are contained in the Hardware Kit: **78-8114-9023-0** (See Section 15).

Arm and Focus Assembly (Beige color) Parts List

Item No.	3M Part Number	Description	Qty.
1	78-8114-8983-6	Shim, Head Leveling	1
2	78-8073-3035-8	Arm, Focus	1
3	78-8120-2920-1	Plate, Standoff	1
4	78-8120-2925-0	Pad, Wear	2
5	78-8064-1601-8	Knob, Focus	1
6	78-8073-3041-6	Cap, Focus Arm	1
7	78-8079-8745-4	Gear, Focus	1
8	(Not available)	Lubricant, Nye Rheolube 368	AR
9	78-8079-8747-0	Bar, Pressure	1
10	78-8079-8743-9	Clamp, Friction	1
11	78-8079-8744-7	Rack, Focus	1
12	26-1009-3653-8	Cap, Post	1

Section 3. Arm and Focus Assembly (Gray color)
(Serial Number 170006497 and below)

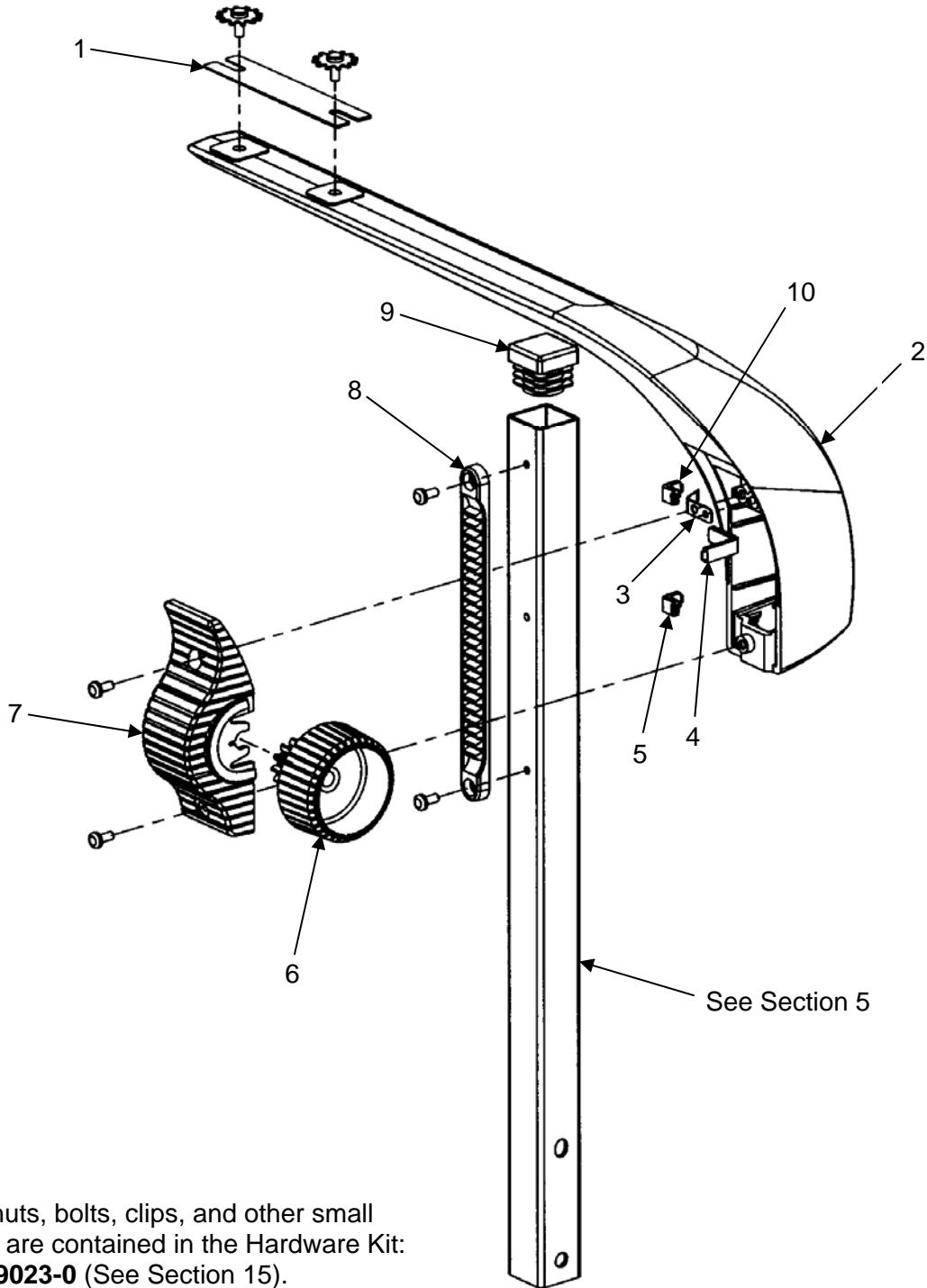

NOTE:
Screws, nuts, bolts, clips, and other small hardware are contained in the Hardware Kit: **78-8114-9023-0** (See Section 15).

Arm and Focus Assembly (Gray color) Parts List
(Serial Number 170006497 and below)

Item No.	3M Part Number	Description	Qty.
1	78-8114-8983-6	Shim, Head Leveling	1
2	78-8120-3045-6	Arm, Focus	1
3	(Not Available)	Spring, Leaf	1
4	78-8120-3069-6	Pad, Rear	1
5	78-8120-3047-2	Pad, Friction, Lower	1
6	78-8120-3048-0	Knob, Gear, Focus	1
7	78-8120-3046-4	Cap, Focus Arm	1
8	78-8079-8744-7	Rack, Focus	1
9	26-1009-3653-8	Cap, Post	1
10	78-8120-4017-4	Pad, Friction. Upper	1

Section 4. Arm/Focus/Post Assembly (Gray color)
 (Serial Number 170006498 and above)

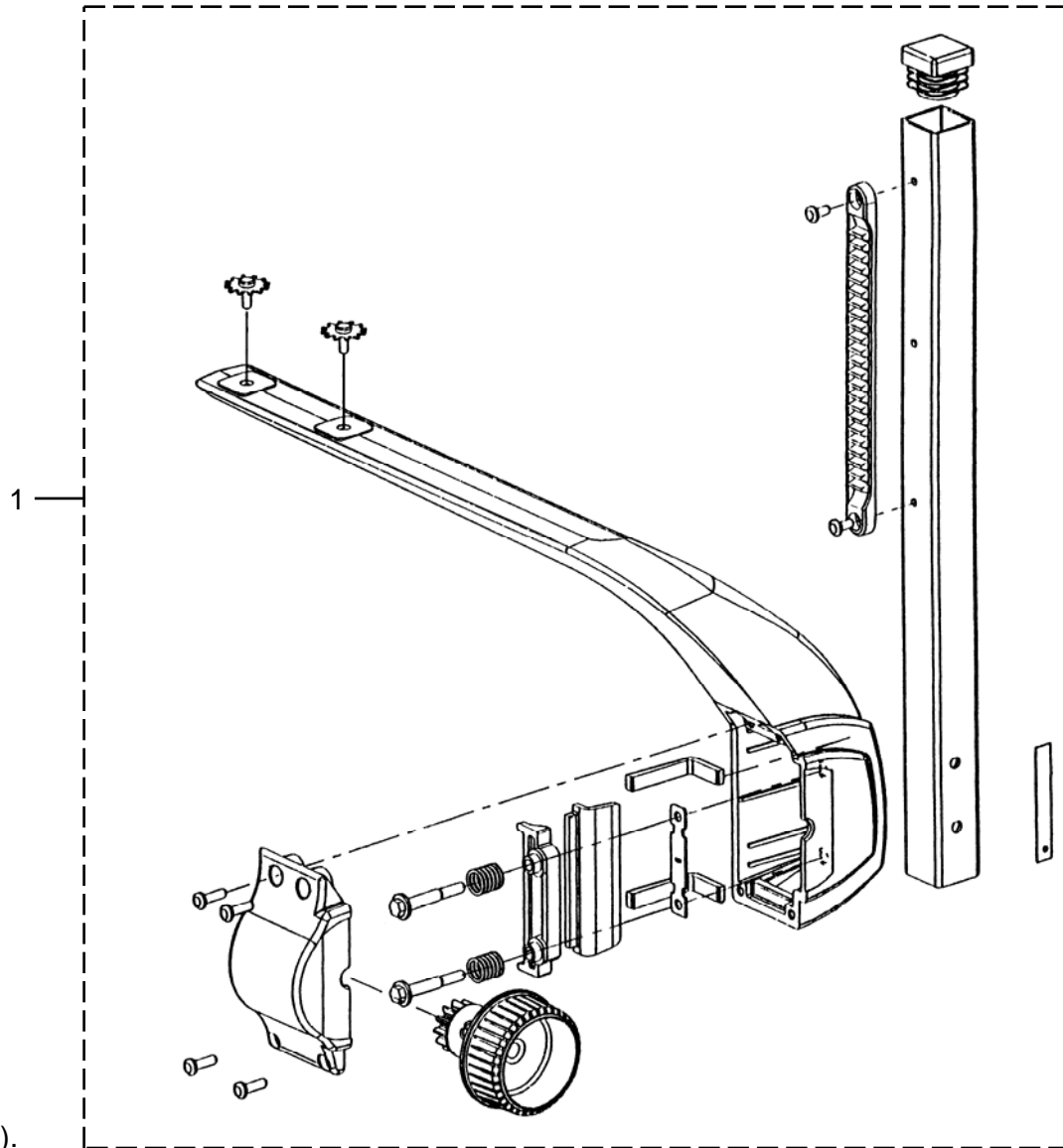

NOTE:
 Screws, nuts,
 bolts, clips, and
 other small
 hardware are
 contained in the
 Hardware Kit:
78-8114-9023-0
 (See Section 15).

Parts List (Serial Number 170006498 and above)

Item No.	3M Part Number	Description	Qty.
1	XO-0038-0891-2	Focus Arm Kit	1

Section 5. Post Assembly

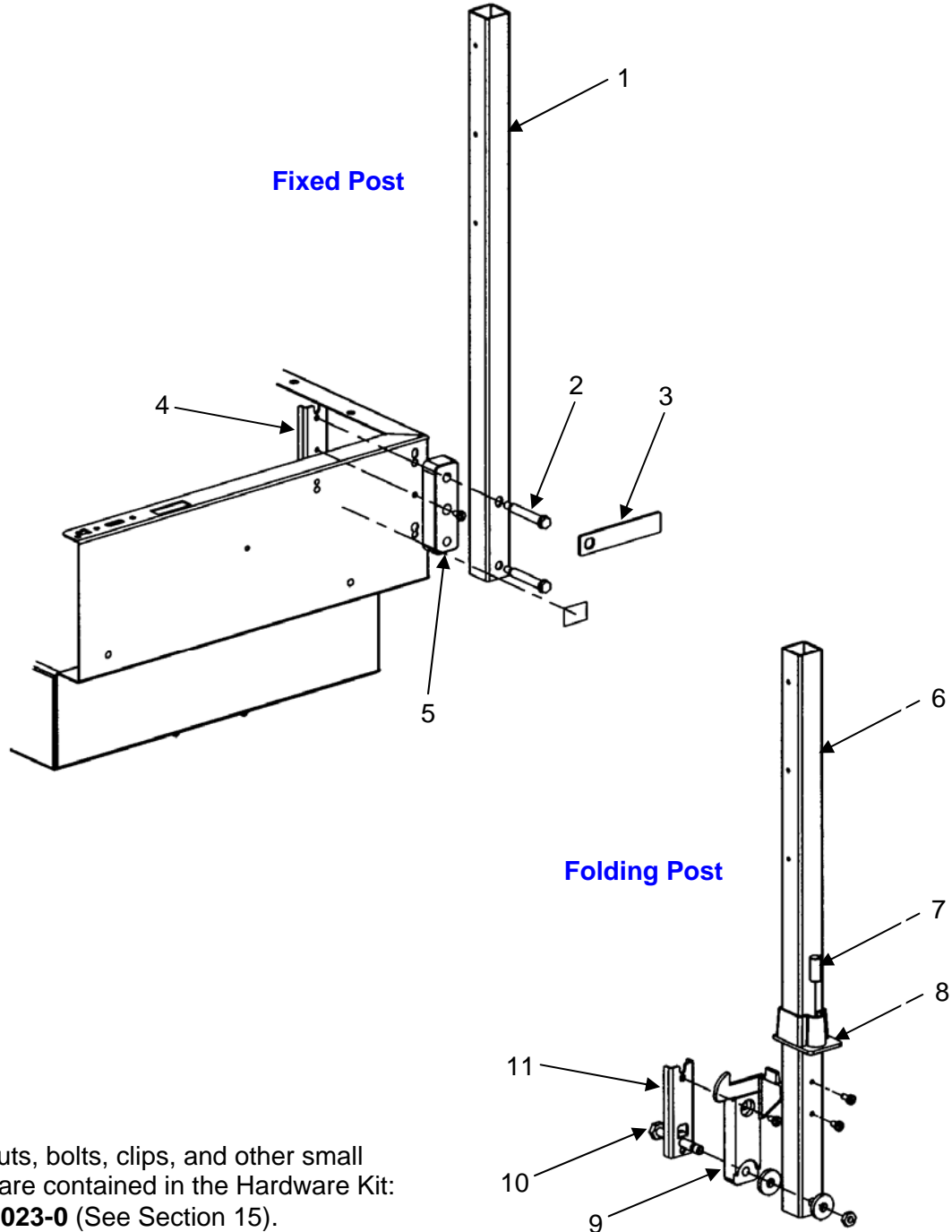

NOTE:
Screws, nuts, bolts, clips, and other small hardware are contained in the Hardware Kit: **78-8114-9023-0** (See Section 15).

Post Assembly Parts List

Item No.	3M Part Number	Description	Qty.
1A	(Not available)	Post (Beige color)	1
1B	(Not available)	Post, Fixed, Offset Rack (Gray color)	1
2	78-8079-8811-4	Bolt, Post	2
3	78-8096-5804-6	Wrench	1
4	78-8079-8810-6	Bracket, Backup	1
5	78-8079-8809-8	Block, Post	1
6	(Not available)	Post, Folding	1
7	(Not available)	Spring, Compression	1
8	78-8079-8852-8	Lock, Post	1
9	78-8079-8875-9	Mount, Post, Pivot	1
10	78-8079-8850-2	Bolt, Pivot	1
11	78-8079-8846-0	Bracket, Pivot	1

Section 6. Top Cover Assembly
(Serial Number 170000988 and below)

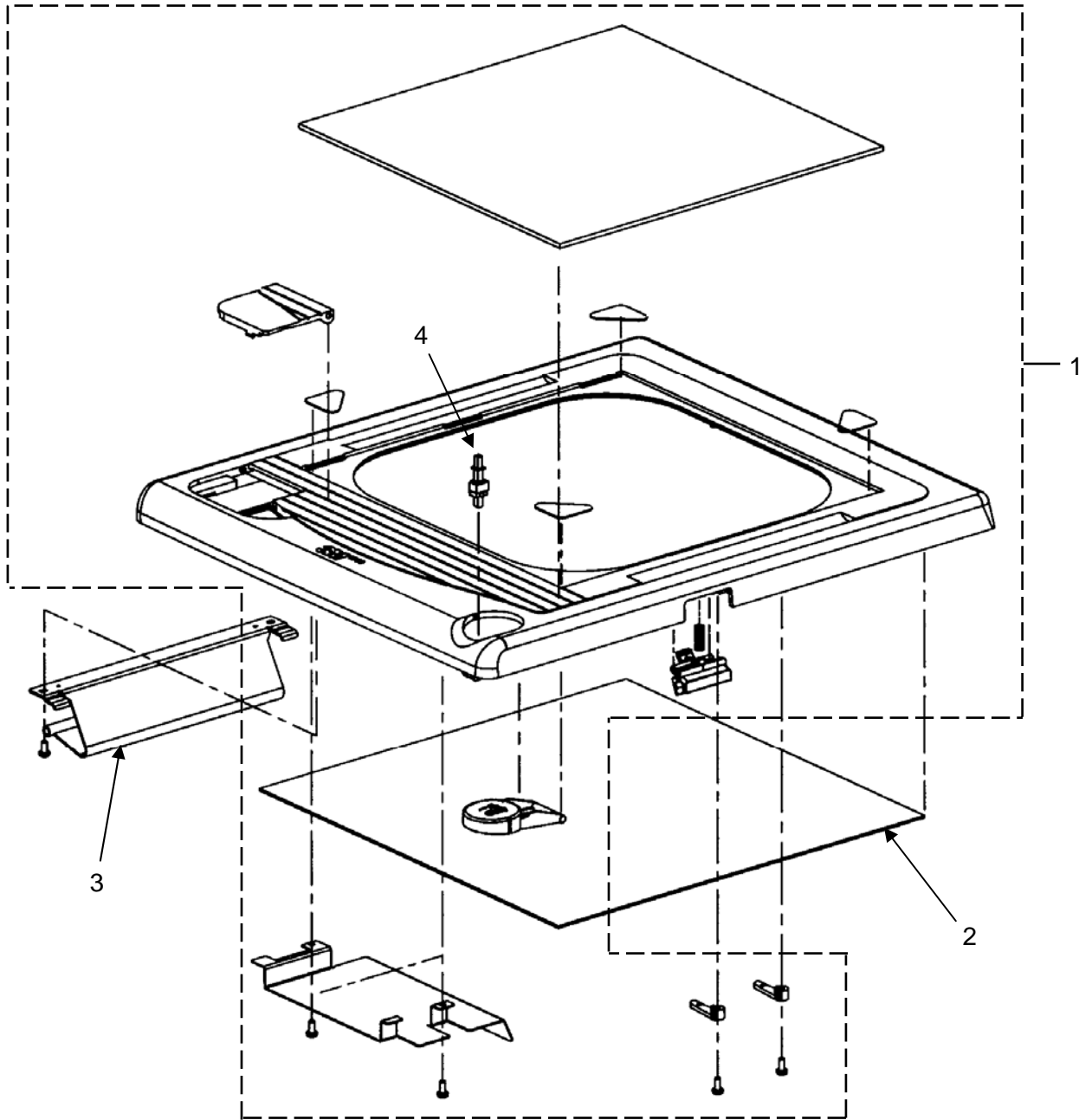

NOTE:

Screws, nuts, bolts, clips, and other small hardware are contained in the Hardware Kit: **78-8114-9023-0** (See Section 15).

Top Cover Assembly Parts List
(Serial Number 170000988 and below)

Item No.	3M Part Number	Description	Qty.
1A	78-8114-9027-1	Top Cover Assembly, Single (Beige color)	1
1B	78-8114-9021-4	Top Cover Assembly, Dual (Beige color)	1
2	(Reference only)	Fresnel Lens (See note below)	1
3	78-8120-2941-7	Bracket, Hinge	1
4	78-8064-1515-0	Actuator Switch	1

NOTE:

If the machine currently has a single-element fresnel lens and a new fresnel is needed, two options are available:

1. Replace the top cover with the appropriate assembly listed in Section 7.
2. Install Kit #78-8121-4740-9. This kit adapts single-element top covers to accept a dual-element fresnel lens.

Refer to Technical Bulletin #10 for additional information.

Section 7. Top Cover Assembly
(Serial Number 170000989 and above)

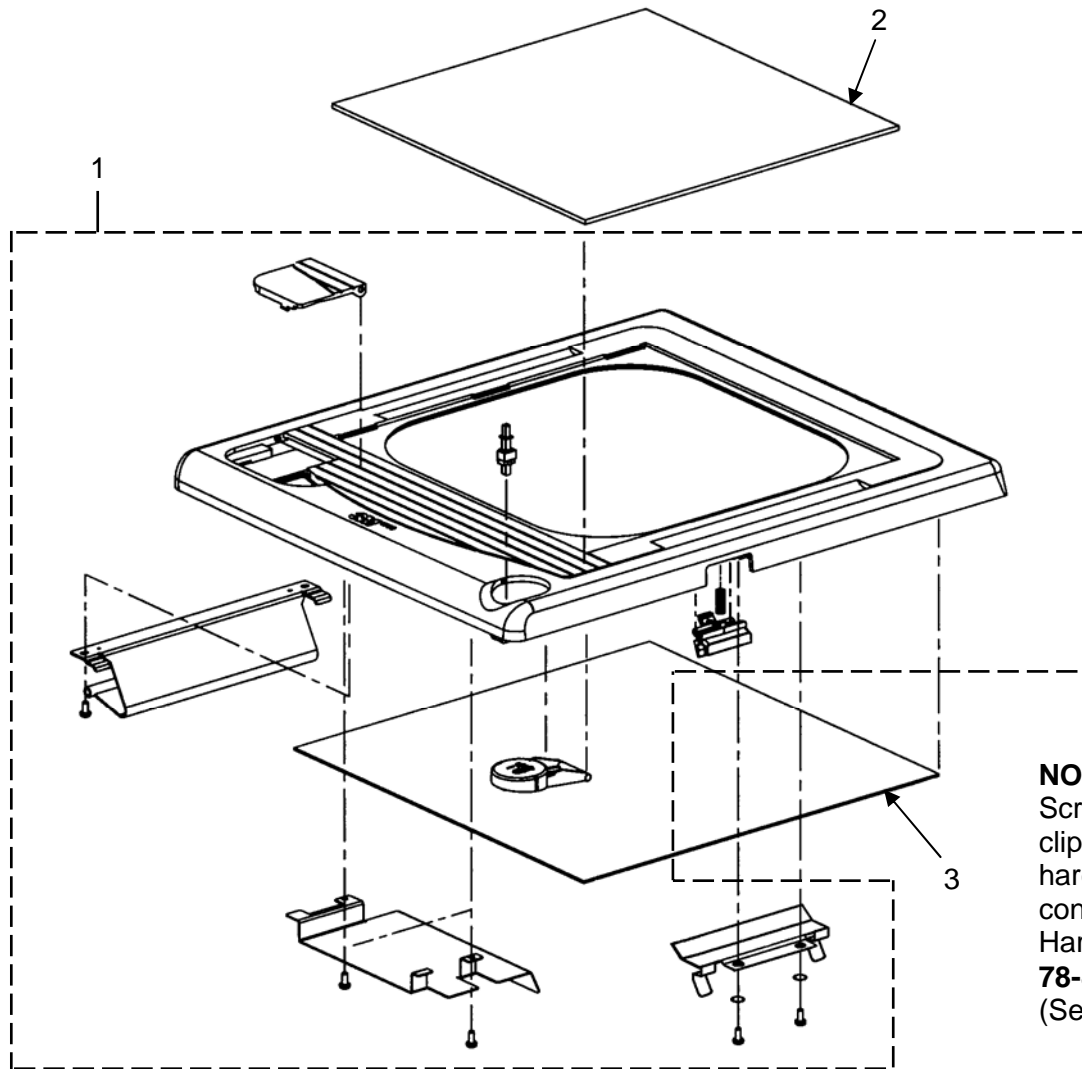

NOTE:
Screws, nuts, bolts, clips, and other small hardware are contained in the Hardware Kit: **78-8114-9023-0** (See Section 15).

Top Cover Assembly Parts List
(Serial Number 170000989 and above)

Item No.	3M Part Number	Description	Qty.
1A	78-8120-8572-4	Top Cover Assembly (Basic - Gray color)	1
1B	78-8120-8573-2	Top Cover Assembly (Lamp Changer - Gray color)	1
2	78-8120-4156-0	Stage Glass	1
3	XO-0038-0820-1	Fresnel Lens, Dual-Element	1
4	78-8064-1515-0	Actuator Switch	1

Section 8. Base Enclosure

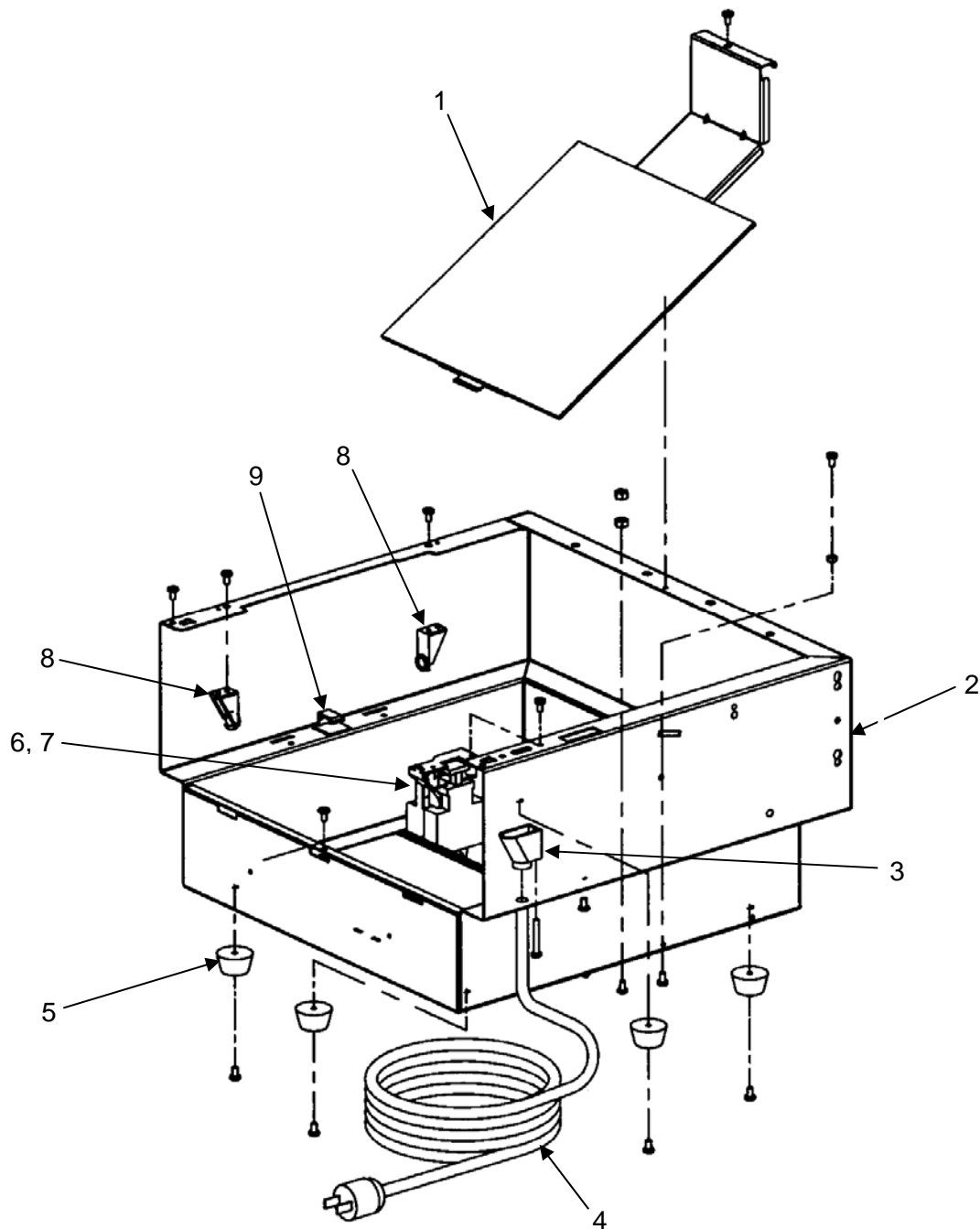

NOTE:
Screws, nuts, bolts, clips, and other small hardware are contained in the Hardware Kit:
78-8114-9023-0 (See Section 15).

Base Enclosure Parts List

Item No.	3M Part Number	Description	Qty.
1	78-8079-9141-5	Body Mirror Assembly	1
2A	(Not available)	Base, Fixed Post (Beige color)	1
2B	(Not available)	Base, Fixed Post (Gray color)	1
2C	(Not available)	Base, Folding Post	1
3	DY-1160-2020-6	Strain Relief	1
4A	78-8079-8822-1	Power Cord, 10 ft., 120V	1
4B	(Not available)	Power Cord, 2 Blade with ground, 127V (Brazil)	1
5	26-1008-5211-5	Foot, Mounting	4
6	78-8073-3039-0	Switch, Interlock Switch	1
7	(Not available)	Cover, Interlock Switch	1
8	78-8079-8817-1	Pivot, Cover	2
9	(Not available)	Clip/Clamp, 0.310 max bundle dia.	1

Section 9. Control Module

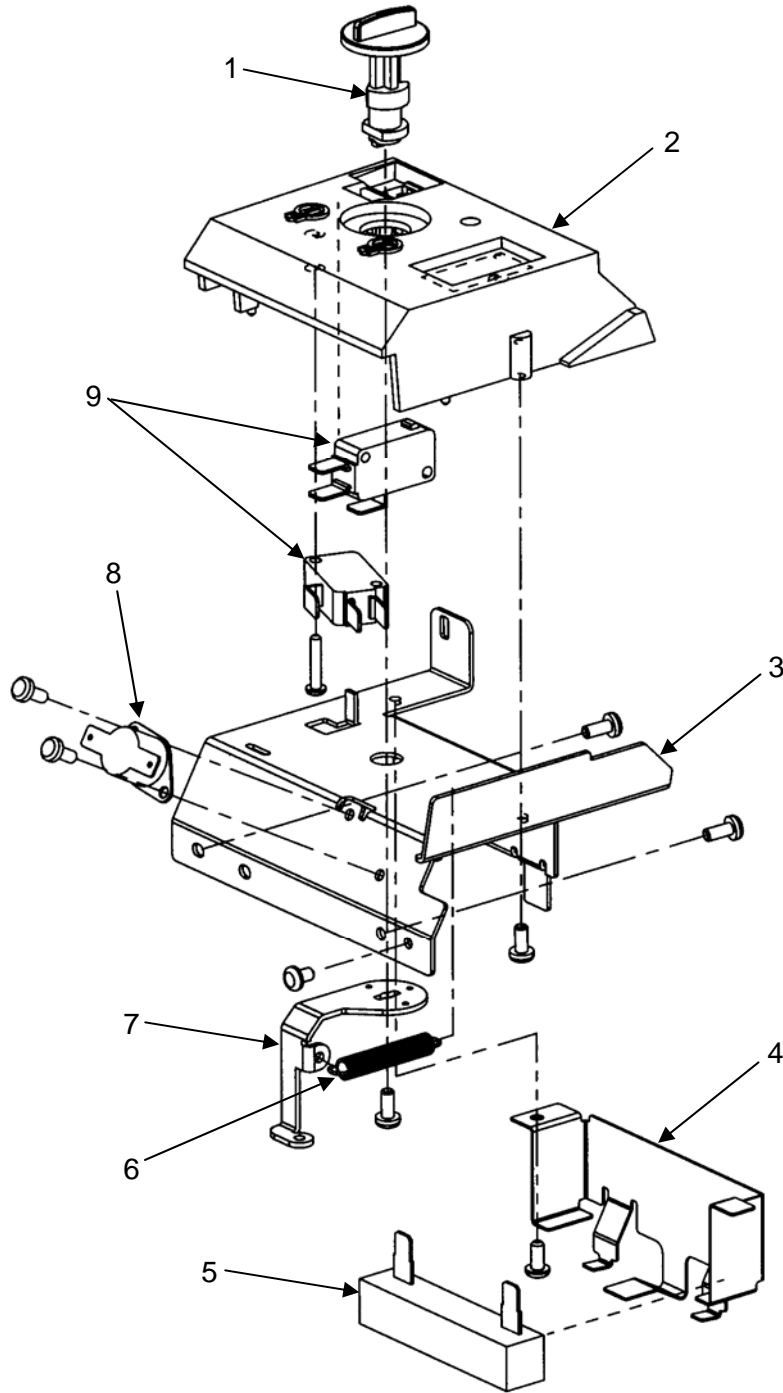

NOTE:

Screws, nuts, bolts, clips, and other small hardware are contained in the Hardware Kit: **78-8114-9023-0** (See Section 15).

Control Module Parts List

Item No.	3M Part Number	Description	Qty.
1	78-8073-2962-4	Knob, Lamp Changer	1
2A	78-8073-2963-2	Housing, Lamp Changer (1 Hole)	1
2B	(Not available)	Housing, Lamp Changer	1
3	78-8073-2961-6	Bracket, Lamp Changer	1
4A	78-8073-3012-7	Cover, Resistor, 20W	1
4B	(Not available)	Bracket, Resistor, 40W	1
5A	78-8073-7127-9	Resistor, 1.2 Ohm, 0.25 tab	1
5B	(Not available)	Resistor, 2.2 Ohm, 0.25 tab	1
6	12-7995-0850-7	Spring, Extension	1
7	78-8079-8881-7	Lever, Lamp Changer	1
8	78-8079-8933-6	Thermostat	1
9	78-8079-8855-1	Switch, Lamp Changer/Dimmer	2
10	78-8114-9017-2	Control Module (entire assembly)	1

Section 10. Lamp Housing (Single)

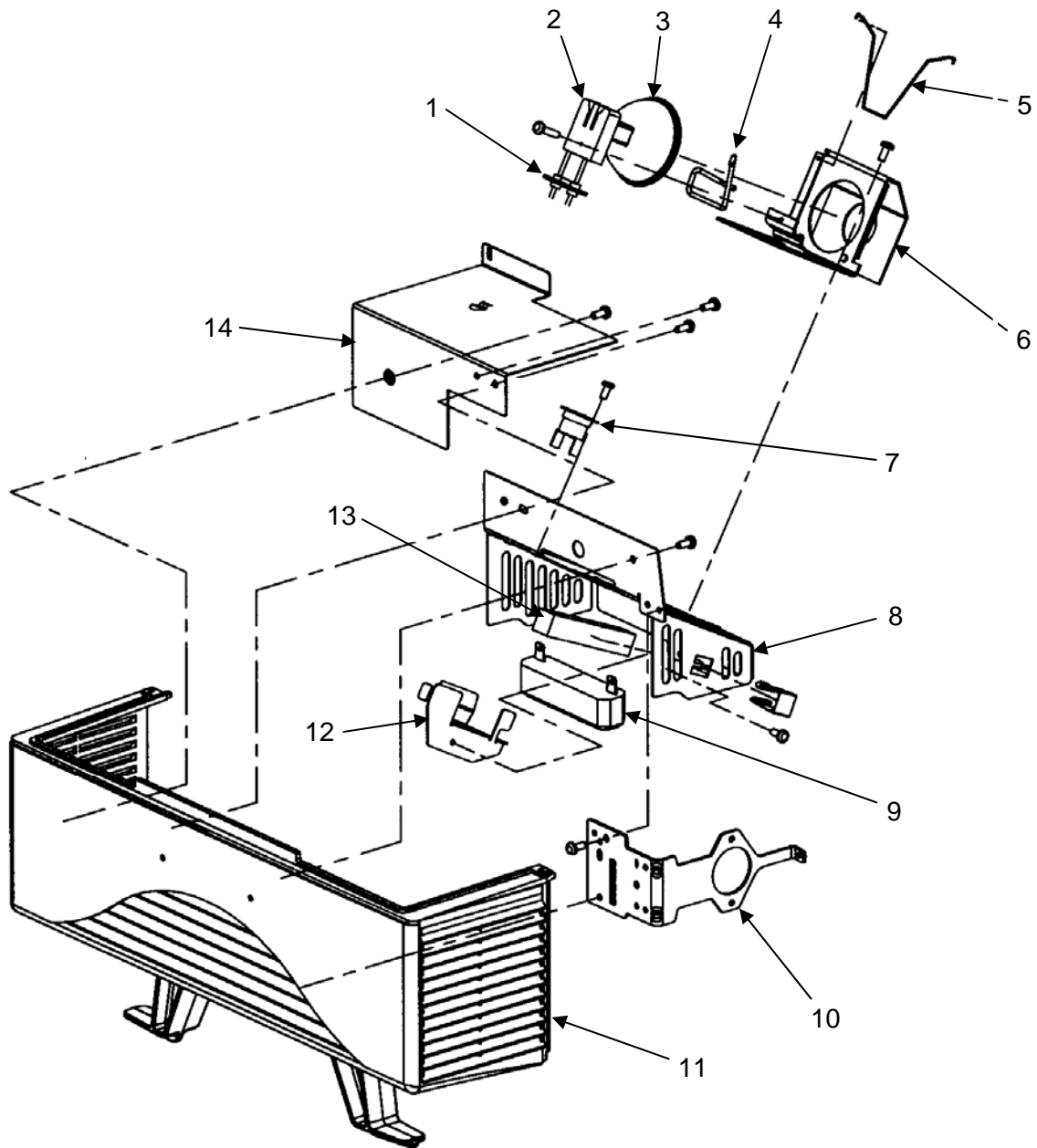

NOTE:

Screws, nuts, bolts, clips, and other small hardware are contained in the Hardware Kit: **78-8114-9023-0** (See Section 15).

Lamp Housing (Single) Parts List

Item No.	3M Part Number	Description	Qty.
1	78-8064-1509-3	Cover, Wire	1
2	78-8079-8820-5	Socket, Single Lamp, ENX	1
3	78-8011-1186-1	Lamp, Projection, ENX, 82V	1
4	78-8064-1491-4	Ejector, Lamp	1
5	78-8064-1510-1	Spring, Lamp, Retaining	1
6	78-8073-7208-7	Bracket, Socket	1
7	78-8079-8872-6	Thermostat, Safety (ENX)	1
8	78-8079-8895-7	Mount, Single Lamp, ENX	1
9	(Not available)	Resistor, 2.2 Ohm, 0.25 tab	1
10	78-8120-2913-6	Bracket, Motor	1
11A	78-8114-9019-8	Housing, Lamp (Beige color)	1
11B	78-8120-8458-6	Housing, Lamp (Gray color)	1
12	(Not available)	Clip, Resistor, 40W	1
13	78-8073-7127-9	Resistor, 1.2 Ohm, 0.25 tab	1
14	78-8079-8840-3	Bracket, Support	1

Section 11. Lamp Housing (Dual)

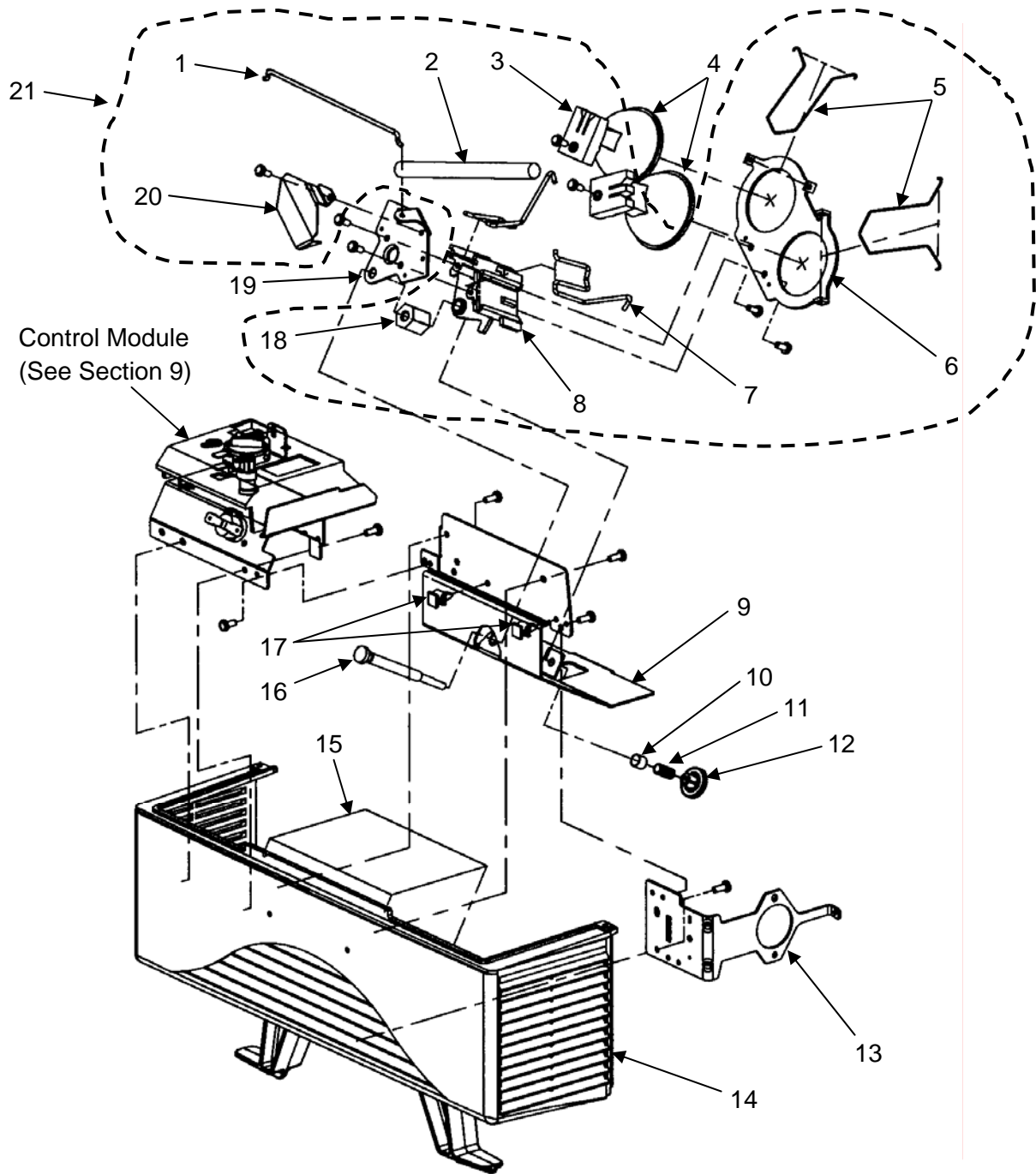

NOTE:
Screws, nuts, bolts, clips, and other small hardware are contained in the Hardware Kit:
78-8114-9023-0 (See Section 15).

Lamp Housing (Dual) Parts List

Item No.	3M Part Number	Description	Qty.
1	78-8079-8887-4	Rod, Lamp Changer	1
2	78-8079-8984-9	Sleeve, Insulator	1
3	78-8073-3017-6	Socket, Dual Lamp, Black	1
4A	78-8011-1186-1	Lamp, Projection, ENX, 82V	1
4B	78-8073-7100-6	Lamp, Projection, FXL, 82V (1745 and 1765)	1
5	78-8079-8863-5	Retainer, Lamp	2
6	(Not available)	Plate, Dual Lamp, ENX	1
7	78-8079-8862-7	Ejector, Lamp	1
8	(Not available)	Pivot, Dual Lamp Mount, ENX	1
9	(Not Available)	Bracket, Lamp Mount, ENX	1
10	26-1009-7186-5	Clip, Shaft, Color Tuning	1
11	26-1009-7485-1	Spring, Compression	1
12	78-8079-8912-0	Knob, Color Tuning	1
13	78-8120-2913-6	Bracket, Motor	1
14A	78-8114-9019-8	Housing, Lamp (Beige color)	1
14B	78-8120-8458-6	Housing, Lamp (Gray color)	1
15	(Not available)	Tape, Reflective, #7323, 3" x 60 yards	1
16	78-8079-8893-2	Shaft, Color Tuning	1
17	(Not Available)	Clip/Clamp, Cable	2
18	(Not Available)	Sleeve, Color Tuning	1
19	78-8079-8858-5	Plate, Dual Socket, ENX	1
20	78-8079-8923-7	Bracket, Wire Cover	1
21	78-8114-9020-6	Dual Lamp Assembly (Items 1,2,3,5,6,7,8,18,20)	

Section 12. Cooling Fan

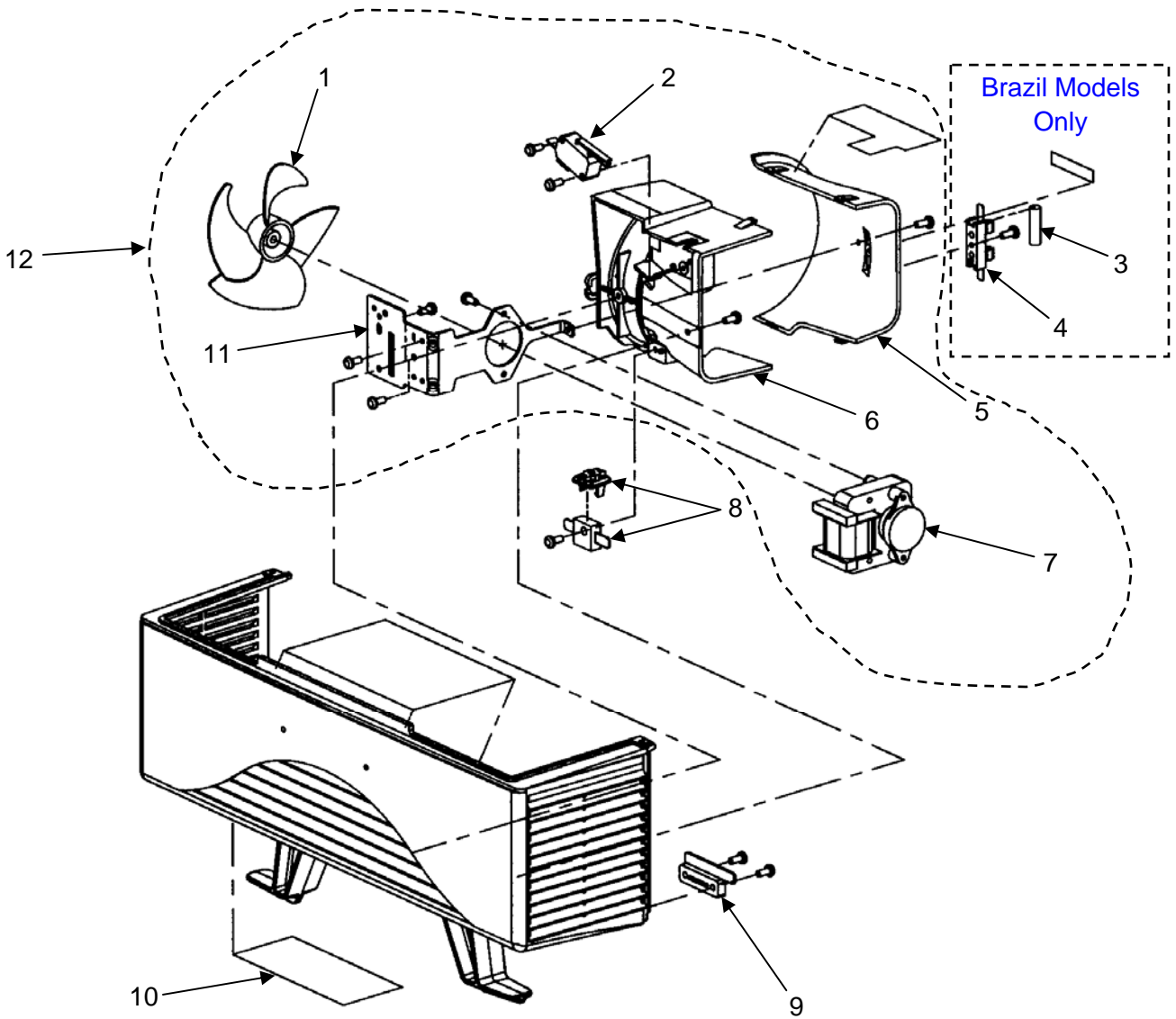

NOTE:

Screws, nuts, bolts, clips, and other small hardware are contained in the Hardware Kit: **78-8114-9023-0** (See Section 15).

Cooling Fan Parts List

Item No.	3M Part Number	Description	Qty.
1	78-8054-1823-9	Blade, Fan	1
2A	(Not available as separate item)	Switch (all models except 1707 AAFB, 1710 AABB, 1720 AACB, and 1760 AANB)	1
2B	(Not available as separate item)	Switch (Models 1707 AAFB, 1710 AABB, 1720 AACB, and 1760 AANB)	1
3	26-1005-9599-5	Fuse, 5 Amp, 5x20mm, Slow Acting (Brazil only)	1
4	26-1005-6624-4	Fuseholder, Block	1
5	78-8079-8873-4	Duct, Fan, Rear	1
6	78-8079-8874-2	Duct, Fan, Front	1
7	78-8120-2914-4	Motor, Fan, 120V	1
8A	78-8054-1836-1	Diode Kit, Inline	1
8B	(Not available)	Diode Kit, Inline (Brazil)	1
9	78-8079-8797-5	Plate, Cord	1
10	(Not available)	Data Nameplate	1
11A	78-8120-2913-6	Bracket, Motor	1
11B	(Not available)	Bracket, Motor (Brazil)	1
12	78-8114-9015-6	Motor Fan Assembly (Items 1, 2, 5, 6, 7, 11)	1

Section 13. Accessories

**Roller Kit
Side-to-Side Installation**

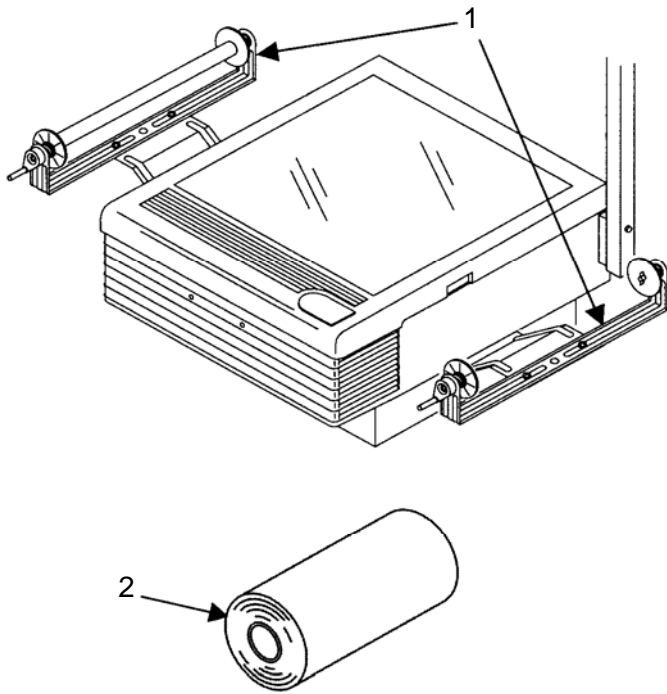

**Roller Kit
Front-to-Rear Installation**

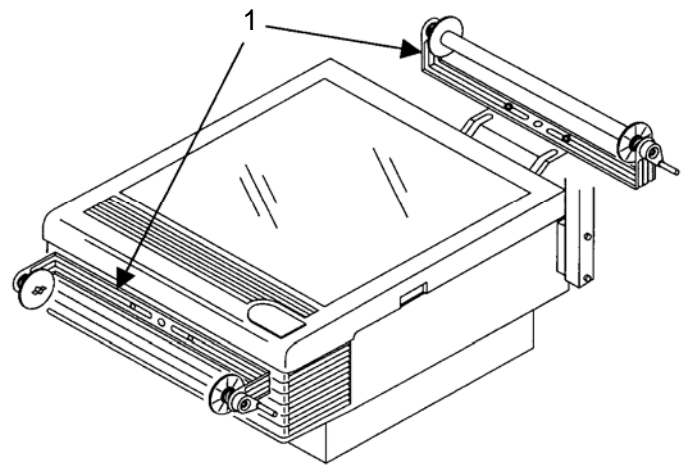

Accessories Parts List

Item No.	3M Part Number	Description	Qty.
1	XO-0038-0750-0	Kit, Roll Film, 10-1/4 inch (260.4mm) (Complete assembly)	1
2	XO-0038-0751-8	Film, Roll, 10-1/4 inch (260.4mm)	1
3	78-6969-7216-1	Dust Cover (Not shown) (Fits all projectors, including those with Roller Kits)	1

Section 14. Wire Jumpers

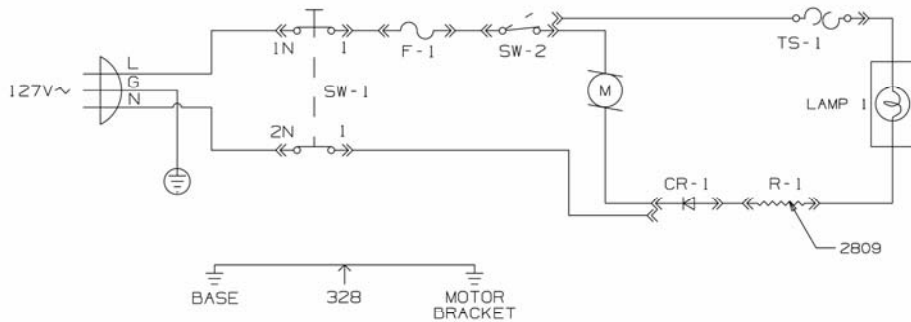

1707 ENX
(Brazil)

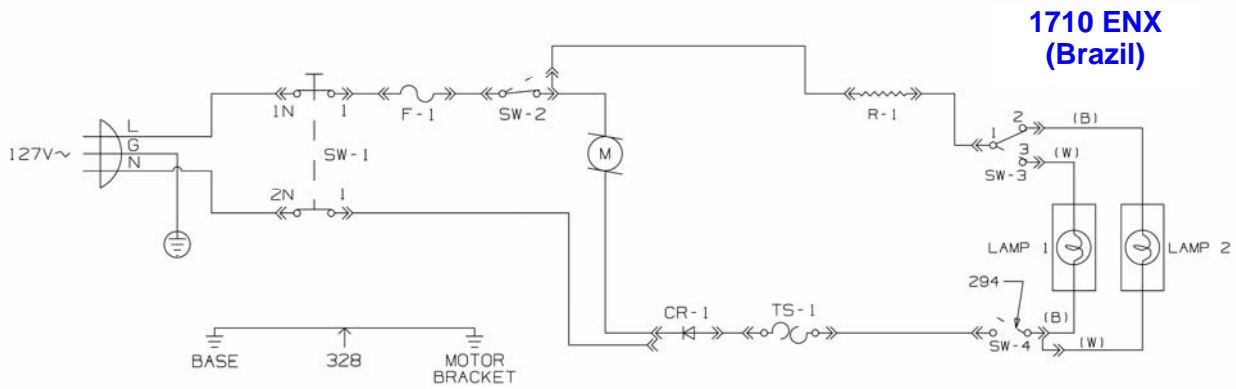

1710 ENX
(Brazil)

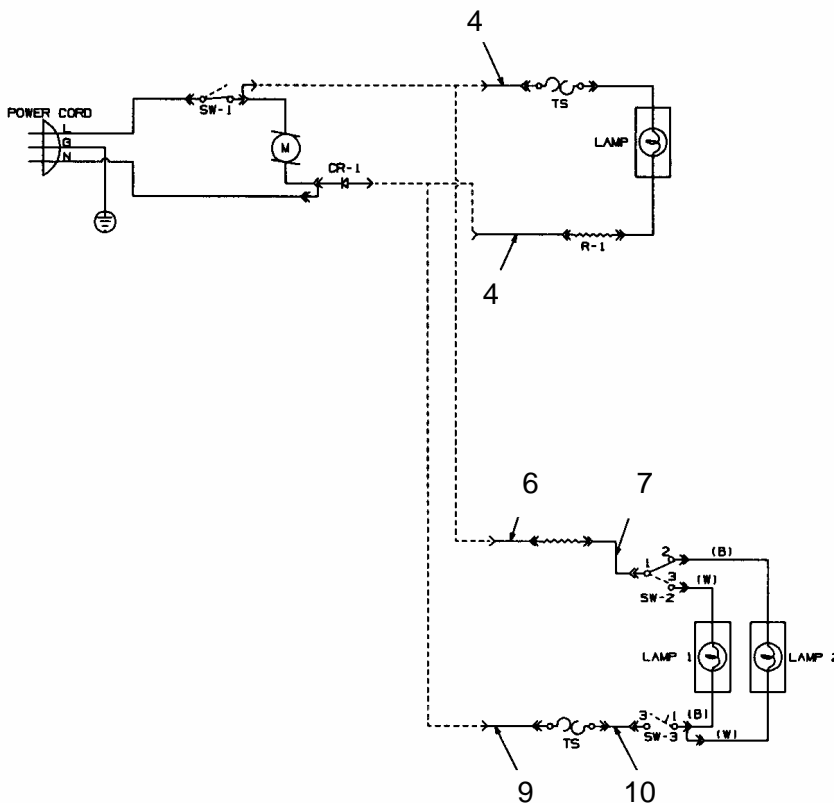

1706/1707 ENX
U.S./Canada/Mexico

1710/1715 ENX
U.S./Canada/Mexico

Wire Jumpers Parts List

Item No.	3M Part Number	Description	Qty.
1	(Not available)	Jumper, 12.5 in., Black (Interlock – On/Off)	1
2	(Not available)	Jumper, 33 in.	1
3	(Not available)	Jumper, Power Switch to Power Supply	1
4	(Not available)	Jumper, 9 in., White	1
5	(Not available)	Jumper, 12.5, White	1
6	(Not available)	Jumper, 12 in.	1
7	(Not available)	Jumper, 5.5 in., Black	1
8	(Not available)	Jumper, 22 in., Insulated	1
9	(Not available)	Jumper, 8.75 in.	1
10	(Not available)	Jumper, 3.5 in., Brown, Insulated	1
11	(Not available)	Jumper, Ground, 18 in., Green/Yellow (Not shown)	1
12	(Not available)	Jumper, 10 in., Black (Switch/Fuse) (Not shown)	1

Section 15. Hardware Kit [\(No Picture\)](#)

Item No.	3M Part Number	Description	Qty.
0	78-8114-9023-0	Hardware Kit	1

APPENDIX A – 1700 SPECIFICATIONS

Country	Power Cord	Alpha	Stock Number	Voltage	Agency	Stage	Head	Handle	Color Tune	Post Type	Lamp	Lamp Changer	Lamp Control	Lamps Installed	Fresnel	Power	Fuse	Cord Storage
Current Models																		
United States	B	1711 BJA	XO-0038-0800-3	120/60	UL / cUL	10 in.	Open Singlet	N	Internal	Fixed	ENX	N	No	1	Dual Element	Diode	No	Y
United States	B	1720 BJV	XO-0038-0801-1	120/60	UL / cUL	10 in.	Closed Singlet	N	Internal	Fixed	ENX	N	No	1	Dual Element	Diode	No	Y
United States	B	1730 AJP	XO-0038-0808-6	120/60	UL / cUL	10 in.	Closed Doublet	N	Internal	Fixed	ENX	N	No	1	Dual Element	Diode	No	Y
United States	B	1740 AJZ	XO-0038-0803-7	120/60	UL / cUL	10 in.	Open Singlet	N	External	Fixed	ENX	Y	No	1	Dual Element	Diode	No	Y
United States	B	1760 BJC	XO-0038-0802-9	120/60	UL / cUL	10 in.	Closed Singlet	N	External	Fixed	ENX	Y	No	1	Dual Element	Diode	No	Y
United States	B	1780 AJK	XO-0038-0806-0	120/60	UL / cUL	10 in.	Closed Doublet	N	External	Fixed	ENX	Y	No	1	Dual Element	Diode	No	Y
Discontinued Models																		
United States	B	1706 AJE	78-9236-6307-0	120/60	UL / cUL	10 in.	Closed Doublet	N	Internal	Fixed	ENX	N	Resistor	1	Single Element	Diode	No	Y
United States	B	1706 AKE	78-9236-6308-8	120/60	UL / cUL	10 in.	Closed Doublet	N	Internal	Fixed	ENX	N	Resistor	1	Single Element	Diode	No	Y
Mexico	B	1707 AAFM	78-9236-6309-6	127/60	NOM	10 in.	Closed Singlet	N	Internal	Fixed	ENX	N	Resistor	1	Single Element	Diode	No	Y
United States	B	1707 AJF	78-9236-6310-4	120/60	UL / cUL	10 in.	Closed Singlet	N	Internal	Fixed	ENX	N	Resistor	1	Single Element	Diode	No	Y
United States	B	1707 AKF	78-9236-6311-2	120/60	UL / cUL	10 in.	Closed Singlet	N	Internal	Fixed	ENX	N	Resistor	1	Single Element	Diode	No	Y
Mexico	B	1710 AABM	78-9236-6312-0	127/60	NOM	10 in.	Closed Singlet	N	External	Fixed	ENX	Y	Resistor	1	Single Element	Diode	No	Y
United States	B	1710 AJB	78-9236-6313-8	120/60	UL / cUL	10 in.	Closed Singlet	N	External	Fixed	ENX	Y	Resistor	1	Single Element	Diode	No	Y
United States	B	1710 AKB	78-9236-6314-6	120/60	UL / cUL	10 in.	Closed Singlet	N	External	Fixed	ENX	Y	Resistor	1	Single Element	Diode	No	Y
United States	B	1715 AJG	78-9236-6315-3	120/60	UL / cUL	10 in.	Closed Doublet	N	External	Fixed	ENX	Y	Resistor	1	Single Element	Diode	No	Y

Discontinued Models (continued)																		
Country	Power Cord	Alpha	Stock Number	Voltage	Agency	Stage	Head	Handle	Color Tune	Post Type	Lamp	Lamp Changer	Lamp Control	Lamps Installed	Fresnel	Power	Fuse	Cord Storage
United States	B	1715 AKG	78-9236-6350-0	120/60	UL / cUL	10 in.	Closed Doublet	N	External	Fixed	ENX	Y	Resistor	1	Single Element	Diode	No	Y
Brazil	A	1720 AACB	78-9236-6316-4	127/60	--	10 in.	Open Singlet	N	Internal	Fixed	ENX	N	Resistor	1	Single Element	Diode	No	Y
Mexico	B	1720 AACM	78-9236-6312-3	127/60	NOM	10 in.	Closed Singlet	N	Internal	Fixed	ENX	N	Resistor	1	Single Element	Diode	No	Y
United States	B	1745 AJM	78-9236-6599-2	120/60	UL / cUL	10 in.	Open Singlet	N	External	Folding	FXL	Y	Resistor	1	Single Element	Diode	No	Y
Brazil	A	1760 AANB	78-9236-6314-9	127/60	--	10 in.	Closed Singlet	N	External	Fixed	ENX	Y	Resistor	1	Single Element	Diode	No	Y
Mexico	B	1760 AANM	78-9236-6315-6	120/60	NOM	10 in.	Open Singlet	N	External	Fixed	ENX	Y	Resistor	1	Single Element	Diode	No	Y
United States	B	1765 AJL	78-9236-6600-8	120/60	UL / cUL	10 in.	Closed Singlet	N	External	Folding	FXL	Y	Resistor	1	Single Element	Diode	No	Y

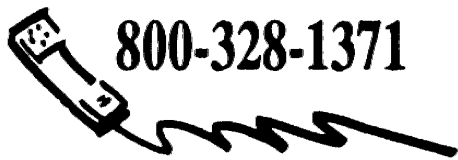

800-328-1371



<http://www.3M.com/meetings>

Important Notice

All statements, technical information, and recommendations related to 3M's products are based on information believed to be reliable, but the accuracy or completeness is not guaranteed. Before using this product, you must evaluate it and determine if it is suitable for your intended application. You assume all risks and liability associated with such use. Any statements related to the product which are not contained in 3M's current publications, or any contrary statements contained on your purchase order shall have no force or effect unless expressly set forth in a written agreement signed by an authorized officer of 3M.